

WUNDERKIND **CUSTOM**

Installation manual and safety information

Risers



BMW R18

From model year 2021



Caution



Important safety advice:

- Working on motorcycles poses a safety risk. Some work may only be carried out by appropriately qualified personnel. Faulty work can have serious consequences and may pose a threat to life and health. Only undertake installation works if you are sufficiently qualified and have an official workshop manual as well as all relevant service notifications available. Otherwise, we strongly recommend that the installation is carried out or at least checked in a specialist workshop.
- Any work in relation to the installation, removal and tightening torque of original parts should always be carried out in compliance with the workshop manual.
- All screws must be attached with thread-locking fluid. However, this should only be done after the installation is complete.
- It is your responsibility to check the product regularly and to determine if a service or replacement is required.
- Please bear in mind that some products are safety-relevant parts of your vehicle. After a fall or collision, check the product and if there is the slightest indication of damage, you must completely replace it.
- Some products require registration.
- These products have been designed for a standard vehicle. ABM® Fahrzeugtechnik GmbH makes no warranty or guarantee of any kind for any damages whatsoever arising out of the combination with other component parts not tested by ABM, as a consequence of improper installation or inadequate maintenance.
- Brake fluid may damage painted surfaces and fairings. Use suitable means to protect all of the surfaces against damage.

1 Preparation

- Please read the entire safety information and installation manual carefully.
- A motorcycle not securely positioned can fall over during the following work. Therefore, make sure that the motorbike is positioned on solid, flat ground and is secured against falling over and rolling away.
- Keep children and pets away from the work area.
- Protect removed parts from damage.
- Please note when disassembling individual parts which screws are used to fasten them. Keep these parts and screws and unless specified otherwise, reuse when assembling.

2 Content

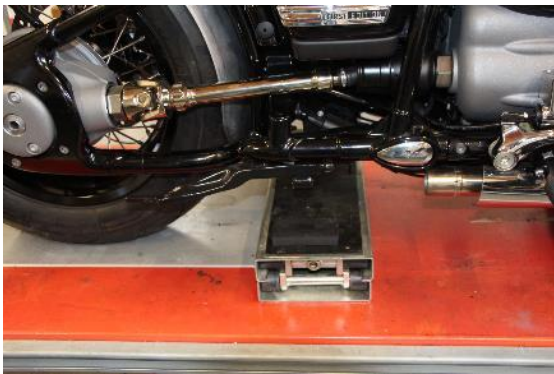

Make sure that the motorbike is securely positioned.

Cover all parts in the handlebar area (tank, speedometer, fender).



Loosen the two screws of the original risers under the top yoke by approx. 5 rotations.

Fully loosen the screws of the upper riser shells.

Carefully place down the handlebar toward the front.



Fully loosen both screws under the top yoke.



Remove original screws and bushings.



Use the bushings provided for installation.



Attach the new handlebar risers as follows:

From below, push the two screws provided together with the washers and two bushings into the top yoke.

From above, insert two further bushings into the top yoke and screw the riser onto the thread (see drawing).



Insert the handlebar into the risers, align and attach lightly.

Next, fasten the risers from below using the two screws (M10).

Tightening torque 48 Nm

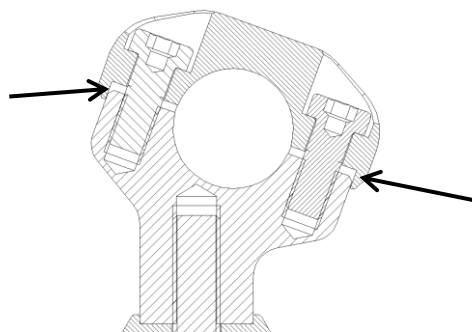

Caution:

During installation, make sure that there is a gap on both sides between top and bottom and no surface touches anything.



Align the handlebar as desired and tighten.

Tightening torque 25 Nm

Push in the plastic covers.



After the final assembly, check the freedom of movement of the brakelines and wires and fasten them only to such an extent that they are not bent, do not chafe and are tension-free in maximum steering angle and over the entire spring travel.



Fasten all screws with thread-locking fluid (medium strength) and the preset tightening torque.

4 Final check

- Make sure that all operating elements present on the handlebar are adequately positioned, even in maximum steering angle. The brake and clutch cylinders must be in an adequate operating position.
- Pay attention to the freedom of movement of the handlebar, its mounted parts and adequate steering angle to each side. The handlebar must be able to be moved easily from side to side. Check the free play of the throttle cable: In maximum steering angle to both sides and with the engine running, the motor speed must not change.
- After completing the work, check the firm fit, function and tightness of all components and screws. Make sure that there is sufficient brake fluid in the reservoir. Also check the front wheel's freewheel and the functionality of the brake system. Further, the function of the clutch, the throttle grip, the electric system and the anti-theft devices must be checked.
- Afterwards, a test drive must be carried out! After completion of the test drive, all screw connections must be re-checked for firm fit, tightness and all movable parts for adequate freedom of movement. Re-test the front wheel's freewheel and check the brake system for overheating. Check the brake fluid level in the reservoir for significant changes.

